

General guidelines on how to manufacture 6.01.01.0



Table of contents

1	Aim and purpose	1
2	Scope / responsibility	2
2.1	Relevant documents.....	2
3	Work description.....	3
3.1	Indications on drawings and references on standards	3
3.1.1	Dimensions and tolerances	3
3.1.2	Threads.....	4
3.1.3	Wrench sizes	4
3.1.4	Surface details	5
3.1.5	Edge conditions.....	5
3.2	Marking and identification of workpieces	6
3.3	Engravings.....	6
3.4	Weldings / solderings.....	6
3.5	Casting parts	7
3.5.1	General	7
3.5.2	Cast iron	7
3.5.3	Steel casting	7
3.5.4	Malleable cast iron	8
3.5.5	Spheroidal graphite cast iron	8
3.5.6	Austenitic cast irons	8
3.5.7	Light metal casting	8
3.6	Thermal treatment	8
3.7	Tightening torque for screw connections.....	9
3.8	Sealants and their application.....	13
3.9	Corrosion protection / surface treatment.....	14
3.9.1	Coating of parts.....	15
3.9.2	Anodising.....	16
3.10	Cleanliness of parts	17
3.11	Packaging / transport insurances	17
3.12	Purchase orders and valid documents	17
3.12.1	Validity of documents / modifications.....	17
3.12.2	Ordering process.....	17
3.13	Examination / complaint.....	17

1 Aim and purpose

These factory standards supplement the existing manufacturing documents and drawings in terms of mechanical production and thus describe the general requirements, the "State of the Art".

2 Scope / responsibility

Responsible for the update of these factory standards is the product development's standardisation department.

❖ *This issue replaces all previous issues!*

2.1 Relevant documents

The versions of the standards specified in the drawings and manufacturing guidelines apply.

3 Work description

These factory standards refer to all parts and assemblies that will be manufactured on behalf of the company **Heye International GmbH**.

All requirements that go beyond those that are described here must be mentioned in the drawings or in the purchase order text.

If there should be deviations between the "General guidelines on how to manufacture" and the statements made in other documents they have to be clarified in each individual case with the materials requirements planner from Heye (the respective name is mentioned in the purchase order). This consultation also has to be made if details in drawings cannot be identified without doubt (example: scaled-down drawings) or if they contradict with the current standards.

3.1 Indications on drawings and references on standards

3.1.1 Dimensions and tolerances

Illustrations in CAD drawing files are usually drawn to scale, anyhow, dimensions may not be taken from the drawings. If dimensions on the drawing should be mentioned several times that one with the highest tolerance requirement will apply.

❖ *The principle to be applied always is: "in case of doubt consult Heye International!"*

Due to existing dimensional stability that cannot be compared with metal, for plastic parts to be produced special requirements are applicable that are mentioned in each individual case on the drawings. The following standards apply:

DIN EN ISO 128-3:2024-06	Technical product documentation - General principles of representation – Part 3: Views, sections and cuts
DIN ISO 5456-2:1998-04	Technical drawings – Projection methods – Part 2: Orthographic representations
DIN EN ISO 128-2:2023-06	Technical product documentation - General principles of representation – Part 2: Basic conventions for lines
DIN EN ISO 1:2022-10	Geometrical product specifications (GPS) - Standard reference temperature for geometrical product specifications and verification
DIN EN ISO 129-1:2022-02	Technical product documentation – Presentation of dimensions and tolerances – Part 1: General principles
DIN 475-1:2016-11	Wrench sizes
DIN ISO 1101:2017-09	Geometrical product specifications (GPS) - Geometrical tolerancing - Tolerances of form, orientation, location and run-out
DIN ISO 2768-1:1991-06	General tolerances; tolerances for linear and angular dimensions without individual tolerance indications Table 1 Linear dimension: "m" Table 2 Chamfers: "m" Table 3 Angular dimensions: "m"

DIN ISO 2768-2:1991-04	General tolerances; geometrical tolerances for features without individual tolerances indications Table 1 Straightness and evenness: "K" Table 2 Rectangularity: "K" Table 3 Symmetry: "K" Table 4 Concentricity: "K"
------------------------	---

The principle of tolerance is fundamentally based on the envelope principle according to SIZE ISO 14405 (E), unless the drawing explicitly refers to the independence principle according to DIN ISO 8015.

3.1.2 Threads

The following standards apply:

DIN 202:1999-11	Screw threads - General plan
DIN 76-1:2016-08	Thread run-outs and thread undercuts
DIN 13-1:1999-11	ISO general purpose metric screw threads
DIN EN 10226-1:2004-10	Pipe threads where pressure tight joints are made on the threads
DIN EN ISO 228-1:2003-05	Pipe threads where pressure tight joints are not made on the threads

The thread depths mentioned on the drawings refer to the usable thread length and must be strictly observed.

Internal threads that are dimensioned on the drawings with "R" always refer to the DIN EN 10226 and must be manufactured as cylindrical internal thread "Rp".

3.1.3 Wrench sizes

Even without particular notice all statements referring to wrench sizes mentioned on drawings are tolerated according to DIN 475.

3.1.4 Surface details

The following standards apply:

DIN EN ISO 1302:2002-06	Geometrical Product Specifications (GPS) - Indication of surface texture in technical product documentation
DIN EN ISO 4288:1998-04	Geometrical Product Specifications (GPS) - Surface texture: Profile method - Rules and procedures for the assessment of surface texture

3.1.5 Edge conditions

All workpiece edges have to be deburred. As far as no further statements are made on the drawings the following applies:

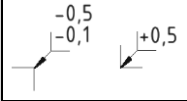
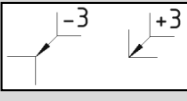
DIN ISO 13715:2020-01	<p>Technical drawings - Edges of undefined shape - Vocabulary and indication on drawings</p> <ul style="list-style-type: none"> ❖ For machining and laser cutting: <ul style="list-style-type: none"> - outside and inside maximum 0.5 mm chamfer or curve. - outside minimal 0,1 mm chamfer or curve (no ridge, not sharp-edged)  <ul style="list-style-type: none"> 2. For flame cuttings and cast raw parts: <ul style="list-style-type: none"> - outside and inside maximum 3 mm chamfer or curve. 
-----------------------	--

3.2 Marking and identification of workpieces

Each component must be marked durably in a suitable manner with the following information:

WWWWWWWWW XXX YYYYYYYYYYY ZZ Gekennzeichnet mit: -Artikel-Nr. (Material-Nr.) [W] -Herstellerkennzeichen [X] -Dokument-Nr. [Y] -Versions-Nr. [Z] marked with: -article-identification-no. (material-identification-no.) [W] -manufacturer-mark [X] -document-identification-no. [Y] -version-no. [Z]
--

In some cases the material number is not identical with the drawing/document number;
 example: drawing in tabular form for several materials.

The position of the marking shall be mentioned on the drawing. If not, only one position will come into consideration that neither is to be seen as function surface nor as contact surface.

Function/contact surfaces are those that are machined right from the beginning as Ra 6.3 or finer.

❖ *The principle to be applied always is: "in case of doubt consult Heye International"!*

Also assemblies are marked, provided that they do not get a name plate.

3.3 Engravings

Engravings have to be manufactured according to the details given on the drawings. If there are no further details on the drawings, the following applies:

Font: Helvetica condensed Engraving depth: 0.5 mm
--

❖ *The principle to be applied always is: "in case of doubt consult Heye International"!*

3.4 Weldings / solderings

For weldings/solderings without rework the minimum requirement is:

DIN EN ISO 13920:2023-08	General tolerances for welded constructions - Dimensions for lengths and angles; shape and position General tolerances for: Degree of accuracy: "B" according to table 1 length Degree of accuracy: "B" according to table 2 angularity Degree of accuracy: "F" according to table 3 straightness/ evenness/ parallelism
--------------------------	--

3.5 Casting parts

3.5.1 General

For raw/casting parts that prove to be erroneous during machining (e.g. faults or distortions), immediately a complaint has to be made and the machining has to be stopped in order to limit the reject costs (latest after the third reject part these measures should be in force.)

If there are uncertainties regarding the kind of set-up of the raw part or position of the machining compared to the raw part, this must immediately be clarified with the materials requirements planner from Heye (mentioned in the purchase order).

DIN EN 1559-1:2011-05	Founding - Technical conditions of delivery – Part 1: General
DIN CEN ISO/TS 8062-2:2014-03; DIN SPEC 91184:2014-03	Geometrical Product Specifications (GPS) - Dimensional and geometrical tolerances for moulded parts – Part 2: Rules

3.5.2 Cast iron

DIN EN 1561:2024-03	Founding - Cast iron with lamellar graphite
DIN CEN ISO/TS 8062-2:2014-03; DIN SPEC 91184:2014-03	Geometrical Product Specifications (GPS) - Dimensional and geometrical tolerances for moulded parts – Part 2: Rules

Especially the hardness of the surface to be machined later may not exceed the value 190+30 Brinell hardness (HB).

Information in purchase order texts:

- Raw part GG-..
- HB190+30
- GTB 17

3.5.3 Steel casting

DIN EN 10293:2015-04	Steel casting and forgins - Steel castings for general engineering uses
DIN CEN ISO/TS 8062-2:2014-03; DIN SPEC 91184:2014-03	Geometrical Product Specifications (GPS) - Dimensional and geometrical tolerances for moulded parts – Part 2: Rules

Information in purchase order texts:

- Raw part GS-..
- HB190+30
- GTB 17

3.5.4 Malleable cast iron

DIN EN 1562:2019-06	Founding - Malleable cast iron
DIN CEN ISO/TS 8062-2:2014-03; DIN SPEC 91184:2014-03	Geometrical Product Specifications (GPS) - Dimensional and geometrical tolerances for moulded parts – Part 2: Rules

3.5.5 Spheroidal graphite cast iron

DIN EN 1563:2019-04	Founding - Spheroidal graphite cast irons;
DIN CEN ISO/TS 8062-2:2014-03; DIN SPEC 91184:2014-03	Geometrical Product Specifications (GPS) - Dimensional and geometrical tolerances for moulded parts – Part 2: Rules

Information in purchase order texts:

- Raw part GGG-..
- HB190+30
- GTB16

3.5.6 Austenitic cast irons

DIN EN 13835:2012-04	Founding - Austenitic cast irons
----------------------	----------------------------------

3.5.7 Light metal casting

DIN CEN ISO/TS 8062-2:2014-03; DIN SPEC 91184:2014-03	Geometrical Product Specifications (GPS) - Dimensional and geometrical tolerances for moulded parts – Part 2: Rules
--	---

Information in purchase order texts:

- Raw part GG-..
- HB190+30
- GTB17

3.6 Thermal treatment

The stated hardness, dimensions, tolerances and shape and position tolerances apply for the state of use and installation of manufactured parts. In each individual case special features like hardening process or layer thickness are mentioned on the drawing.

3.7 Tightening torque for screw connections

As far as the drawings do not contain other values the standard tightening torques (see table 1-10) apply.

In the table values for M_A are considered:

- a) Coefficient of friction $\mu_{ges} = 0.12 =$ slightly oiled / $0.14 =$ commercial delivery
- b) Minimum specified yield strength = 90%
- c) Screw material = steel

Standard values for shaft screws with standard thread / Tightening torques M_A in N·m			
Thread	Coefficient of friction $\mu_{ges} = 0,12$ / slightly oiled		
	Strength class		
	8.8	10.9	12.9
M4	3.0	4.6	5.1
M5	5.9	8.6	10,0
M6	10.1	14.9	17.4
M8	24.6	36.1	42.2
M10	48	71	83
M12	84	123	144
M14	133	195	229
M16	206	302	354
M18	295	421	492
M20	415	592	692

Table 1: Standard values for shaft screws with standard thread / Coefficient of friction 0,12

Standard values for shaft screws with standard thread / Tightening torques M_A in N·m			
Thread	Coefficient of friction $\mu_{ges} = 0,14$ / commercial delivery		
	Strength class		
	8.8	10.9	12.9
M4	3.3	4,8	5.6
M5	6.5	9.5	11.2
M6	11.3	16.5	19.3
M8	27.3	40.1	46.9
M10	54.0	79.0	93.0
M12	93.0	137.0	160.0
M14	148.0	218.0	255.0
M16	230.0	338,0	395.0
M18	329.0	469.0	549.0
M20	464.0	661.0	773.0

Table 2: Standard values for shaft screws with standard thread / Coefficient of friction 0,14

Standard values for shaft screws with fine pitch thread / Tightening torques M_A in N·m			
Thread	Coefficient of friction $\mu_{ges} = 0,12$ / slightly oiled		
	Strength class		
	8.8	10.9	12.9
M8x1	26.1	38.3	44.9
M10x1,25	51	75	87
M12x1,25	90	133	155
M12x1,5	87	128	150
M14x1,5	142	209	244
M16x1,5	218	320	374
M18x1,5	327	465	544
M20x1,5	454	646	756

Table 3: Standard values for shaft screws with fine pitch thread / Coefficient of friction 0,12

Standard values for shaft screws with fine pitch thread / Tightening torques M_A in N·m			
Thread	Coefficient of friction $\mu_{ges} = 0,14$ / commercial delivery		
	Strength class		
	8.8	10.9	12.9
M8x1	29.2	42.8	50.1
M10x1,25	57.0	83.0	98.0
M12x1,25	101.0	149,0	174.0
M12x1,5	97.0	143.0	167.0
M14x1,5	159.0	234.0	274.0
M16x1,5	244.0	359.0	420.0
M18x1,5	368.0	523.0	613.0
M20x1,5	511.0	728.0	852.0

Table 4: Standard values for shaft screws with fine pitch thread / Coefficient of friction 0,14



Strength marking on metric screws		
8.8	10.9	12.9
		

Table 5: Strength marking on metric screws

Standard values for shaft screws with UNC-thread / Tightening torques M_A in N·m			
Thread	Coefficient of friction $\mu_{ges} = 0,12$ / slightly oiled		
	Strength class		
	Grade 5 (~8.8)	Grade 8 (~10.9)	ASTM A 574 (~12.9)
#6	1.2	2.5	3.0
#8	3.3	4.7	5.5
#10	4.8	6.7	7.9
1/4	11.0	15.6	18.3
5/16	23.2	32.8	38.6
3/8	40.2	56.8	66.9
7/16	63.9	90.4	106.4
1/2	98.0	138.5	163.1
5/8	192	271	319
3/4	344	486	571
7/8	550	777	915
1	826	1167	1373
1 1/8	1173	1658	1951
1 1/4	1447	2322	2733
1 3/8	1899	3047	3587
1 1/2	2507	4024	4737

Table 6: Standard values for shaft screws with UNC-thread / Coefficient of friction 0,12

Standard values for shaft screws with UNC-thread / Tightening torques M_A in N·m			
Thread	Coefficient of friction $\mu_{ges} = 0,14$ / commercial delivery		
	Strength class		
	Grade 5 (~8.8)	Grade 8 (~10.9)	ASTM A 574 (~12.9)
#6	2,0	2,8	3,3
#8	3,6	5,1	6,1
#10	5,3	7,4	8,7
1/4	12,1	17,1	20,2
5/16	25,7	36,3	42,7
3/8	44,6	63	74,1
7/16	70,9	100	117,9
1/2	109	154	181,1
5/8	213	301	354,5
3/4	383	541	637,2
7/8	614	868	1021,5
1	922	1303	1533,3
1 1/8	1153	1850	2178
1 1/4	1618	2597	3057,2
1 3/8	2121	3405	4007,4
1 1/2	2806	4504	5301,5

Table 7: Standard values for shaft screws with UNC-thread / Coefficient of friction 0,14

Standard values for shaft screws with UNF-thread / Tightening torques M_A in N·m			
Thread Number of threads G	Coefficient of friction $\mu_{ges} = 0,12$ / slightly oiled		
	Strength class		
	Grade 5 (~8.8)	Grade 8 (~10.9)	ASTM A 574 (~12.9)
1/4 - 28	12.4	17.5	20.6
5/16 - 24	25.4	35.8	42.2
3/8 - 24	44.7	63.2	74.4
7/16 - 20	70.2	99.2	116.8
1/2 - 20	108.4	153.2	180.3
5/8 - 18	212	300	353
3/4 - 16	376	531	625
7/8 - 14	602	850	1001
1 - 12	896	1267	1491
1 1/4 - 12	1799	2542	2993
1 1/2 - 12	2778	4459	5249

Table 8: Standard values for shaft screws with UNF-thread / Coefficient of friction 0,12

Standard values for shaft screws with UNF-thread / Tightening torques M_A in N·m			
Thread Number of threads G	Coefficient of friction $\mu_{ges} = 0,14$ / slightly oiled		
	Strength class		
	Grade 5 (~8.8)	Grade 8 (~10.9)	ASTM A 574 (~12.9)
1/4 - 28	13.8	19.5	22.9
5/16 - 24	28.3	40.0	47.0
3/8 - 24	50.0	70.7	83.2
7/16 - 20	78.6	111.0	130.7
1/2 - 20	122.0	172.0	202.2
5/8 - 18	239.0	337.0	396.6
3/4 - 16	423.0	597.0	703.0
7/8 - 14	677.3	957.1	1126.6
1 - 12	1008.6	1425.2	1677.5
1 1/4 - 12	2030.6	2869.4	3377.4
1 1/2 - 12	3568.9	5043.0	5935.9

Table 9: Standard values for shaft screws with UNF-thread / Coefficient of friction 0,14



Strength marking on inch screws		
Grade 5 (~8.8)	Grade 8 (~10.9)	ASTM A 574 (~12.9)
		

Table 10: Strength marking on inch screws

3.8 Sealants and their application

Unless the drawings do not include different specifications, the sealants mentioned in the table below or similar sealants have to be used. Before using the sealant, please make sure that necessary preparations are made as the respective sealant requires (e.g. adhesive surfaces clean and free from grease).

Sealants and their application	
Application	Sealant
Screw locking medium strength	WEICON AN 302-42 / Loctite 242
Screw locking maximum strength	WEICON AN 302-70 / Loctite 270
Join connection	WEICON AN 306-48 / Loctite 648
Surface seal	WEICON AN 305-73 / Loctite 573
Tube and thread sealant	WEICON AN 305-72 / Loctite 572
Silicone seal for bridging larger gaps	Loctite 5660*
Activator for applying a sealant for non-ferrous metals	WEICON ACTIVATOR F
Remarks	
*Loctite 5660 replaces Loctite 5920 which <u>must not</u> be used anymore!	

Table 11: Sealants and their applications

In general applies, that fittings of all kinds must be inserted with a suitable sealant, even if this is not stated on the drawings.

❖ *The principle to be applied always is: "in case of doubt consult Heye International"!*

3.9 Corrosion protection / surface treatment

A sufficient corrosion protection must generally be provided for the duration of manufacture, storage, transport and mounting. Hints on varnishing / priming can be taken from the drawing and purchase order (see examples), function surfaces have to be kept free from varnish. Function/contact surfaces are those that are machined right from the beginning as Ra 6.3 or finer.

Especially the prepared steps for the respective surface treatment (free it from dust, dirt, rust and grease) must be strictly observed.

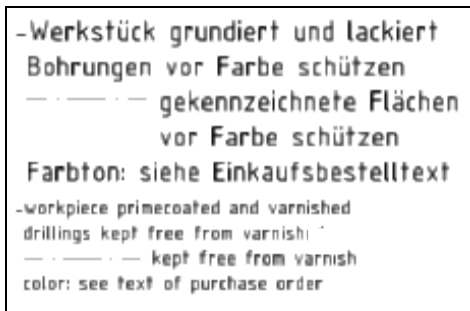

Example: Drawing

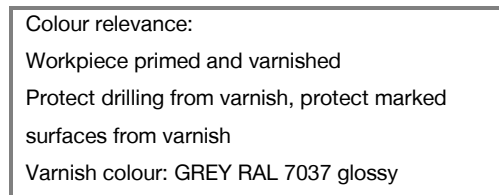

Example: Purchase order text

The following standards apply:

DIN EN ISO 2082:2017-12	Metallic and other inorganic coatings - Electroplated coatings of cadmium with supplementary treatments on iron or steel
DIN 50938:2018-01	Black oxide coatings on iron or steel - Requirements and test methods
DIN EN ISO 4042:2022-11	Fasteners - Electroplated coatings
DIN EN ISO 10684:2011-09	Fasteners - Hot dip galvanized coatings
DIN 55633-1:2021-03	Paints and varnishes - Corrosion protection of steel structures by powder coating systems - Assessment of powder coating systems and execution of coating
DIN 17611:2022-08	Anodised products of wrought aluminium and wrought aluminium alloys - Technical conditions of delivery
DIN EN ISO 12944-1:2019-01	Paints and varnishes - Corrosion protection of steel structures by protective paint systems

3.9.1 Coating of parts

The stated dimensions, tolerances and shape and position tolerances apply for the state of use and installation of manufactured parts.

If requirements concerning the coating can neither be taken from the purchase order text nor from the drawing, the following applies:

<p>International quality guidelines for coating of parts made of</p> <ul style="list-style-type: none"> - Aluminium "GSB AL 631" - Steel and hot-dip galvanized steel "GSB ST 663" <p>Exposure to corrosion C4 according to ISO 12944</p> <p>Minimum layer thickness 160µ</p>

Otherwise the requirements mentioned in the purchase order text as well as on the drawings apply. With respect to the corrosive category the subsequent marks (see table 5) of the drawings have to be used:

Corrosion protection classes according to DIN EN ISO 12944

Corrosive category, corrosion load	Corrosion	Corrosion protection period (class)	Protection period (years)*	Nominal layer thickness In µm	Condensing of water vapour in hours (h)	Reaction time of salt spray fog in hours (h)	Examples for typical environs
C1 Insignificant	Very low less aggressive inside	short	2 to 5 years	70	-	-	Interior rooms: insulated buildings
		medium	5 to 15 years	70	-	-	
		long	more than 15years	70	-	-	
C2 Low	Low moderately aggressive outside/inside	short	2 to 5 years	80	48	-	Slightly contaminated atmosphere: rural areas
		medium	5 to 15 years	120	48	-	
		long	more than 15years	160	120	-	
C3 Moderate	Moderately less aggressive outside/inside	short	2 to 5 years	120	48	120	City / industrial atmosphere with temperate climate
		medium	5 to 15 years	160	120	240	
		long	more than 15years	200	240	480	
C4 Heavy	high moderately aggressive outside/inside	short	2 to 5 years	160	120	240	Industrial / coastal atmosphere with moderate amount of salt
		medium	5 to 15 years	200	240	480	
		long	more than 15years	240-280	480	720	
C5-I Very heavy (Industry)	very high aggressive outside/inside	short	2 to 5 years	200	240	480	Industrial atmosphere with high relative humidity and aggressive atmosphere
		medium	5 to 15 years	240-280	480	720	
		long	more than 15years	320	720	1440	
C5-M Very heavy (Sea)	very high maritime outside/inside	short	2 to 5 years	200	240	480	Coastal areas with high amount of salt
		medium	5 to 15 years	240-280	480	720	
		long	more than 15years	320	720	1440	

***Protection period:** The protection period is no "guarantee period".
 short: 2 to 5 years
 medium: 5 to 15 years
 long: more than 15 years

Table 12: Corrosive category

3.9.2 Anodising

If information on colour or surface processing can neither be taken from the purchase order text nor from the drawing, the following applies:

E6 EV1 / E6 anodising EV1 / intensive etching. Anodising, colour: natural coloured

Otherwise the colours mentioned in the purchase order text as well as the surface processing mentioned on the drawings apply. With respect to the surface processing the subsequent marks (see table 6) of the drawings have to be used:

E0 without removing pre-treatment

After the degreasing and etching (corresponds with E6, see below) the surface treatment will be carried out without other prior worksteps. The surface texture that results from manufacture and/or machining is kept. Existing surface faults like for example grooves, scratches, sinkholes, inclusions etc. remain visible and can even appear intensified. Corrosion signs that cannot be seen before etching or that are only hard to see can also get visible.

E1 ground

By the grinding process unevenness is removed from the surface. By it, it however gets more even, but it looks a little dull. Surface faults are mostly eliminated. Depending on the abrasive grain sizes coarse or fine grinding grooves are visible.

E2 satined

Satin-finishing (or also called brushing) provides for a more even and brighter surface compared with grinding. Satining brush strokes are visible. Grooves, scratches, sinkholes, inclusions etc. can only be removed partly.

E3 polished

Polishing provides for a glossy surface. Surface faults like for example grooves, scratches, sinkholes, inclusions etc. can only be removed in a limited way.

E4 ground and satined

Grinding and satining provides for an even bright surface. Grooves, scratches, sinkholes, inclusions and other surface faults are removed. Corrosion signs that were not visible before are also removed and are – opposite to the processing type E0 or E6 – not visible anymore after surface treatment.

E5 ground and polished

Grinding and polishing provides for a smooth, shiny surface. Grooves, scratches, sinkholes, inclusions, grinding grooves and other surface faults – above all covered corrosion that can get visible during the processing type E0 or E6 – can be removed.

E6 chemically treated by etching

After degreasing and etching normally the surface gets a matt white, slightly silk glossy look. The little grooves and unevenness that follow from the manufacture and/or machining cannot completely be removed, but at best they can be smoothed. Corrosion signs that cannot be seen before etching or that are only hard to see can also get visible by this treatment, irregularities in structure, e.g. strip-shaped abnormal grain growth as well as welding seams can be intensified in particular by the treatment E6.

E7 chemically polished or electropolished

After degreasing the surface, it gets very glossy by a treatment in special chemical or electrolytic baths. Surface faults are only removed partly; corrosion can get visible.

E8 ground, polished and chemical or electrolytic polishing

Grinding and polishing with subsequent treatment in chemical or electrolytic polishing baths provides for a very glossy appearance; mechanical surface faults and beginning corrosion are normally removed.

Table 6: Pre-treatment processes

3.10 Cleanliness of parts

Parts and their hollow spaces must be free from chipping liquids / drilling emulsions, chips, dust and dirt. The parts should be supplied in such a way that no further cleaning is requested before mounting and dispatch. The parts especially must be free from chips and impurities (e.g. cooling lubricants), this also applies when installed and for difficult to access areas. Chemical cleaning methods must be reactionless on the features of the parts. Especially, before varnishing/bonding a suitable cleaning and degreasing of the workpieces must be carried out.

3.11 Packaging / transport insurances

Packaging must be executed in such a way that parts cannot be damaged, especially a suitable impact protection for the function surfaces has to be ensured.

3.12 Purchase orders and valid documents

3.12.1 Validity of documents / modifications

Due to the internal modification procedure for our drawings/documents the identification numbers of the belonging modification notice are notified in the respective field under "Version/ Change".

The supplier must ensure that his manufacturing document is the same as that one mentioned in the purchase order (document-no. / material-no. / version).

3.12.2 Ordering process

To each initial purchase order a valid drawing is attached. If further CAD data should be required, in individual cases they can be received from the materials requirements planner.

❖ *The manufacturing drawing, however, always remains the leading document!*

All drawings remain with the supplier (observe the non-disclosure agreement!).

3.13 Examination / complaint

As far as certain tests are carried out on the supply side, the respective test protocols have to be added to the assemblies/parts supplied.

The supplier has to ensure compliance with the specification. **Heye International GmbH** reserves the right to check the requested features by sampling and to return the complete supply in case of non-compliance.

The General Terms and Conditions apply.