

WE ARE GLASS PEOPLE

HEYE

ROTATING TUBE

Type 2371

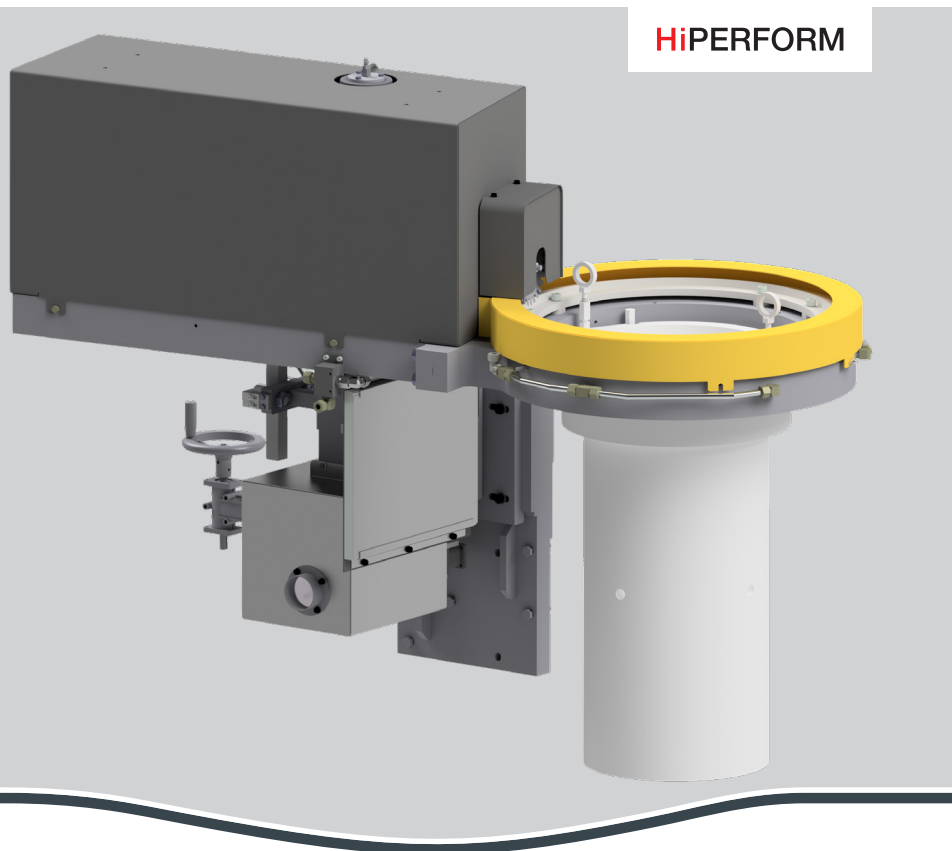

THE ROTATING TUBE

The mechanical design of the tube mechanism provides for high running smoothness and exact alignment of the tube above the center of the job. For NNPB applications the electronic height adjustment is controlled via the Heye Process Control. The redesigned Heye Rotating Tube can be mounted at various feeder types.

Alignment of the tube

The tube mechanism is mounted on a cross slide. This slide can be adjusted via spindles in longitudinal and cross direction. After adjustment the spindles can be locked against accidental misalignment.

Swivel-type

When maintaining or repairing the feeder - for instance when exchanging the spout - the tube mechanism can be swivelled out by 90 degrees after demounting the tube.

Safety

An adjustable limit switch controls the distance between tube and spout.

If a predefined minimum distance is less than permitted the rotational movement of the tube will be stopped to prevent damage to the tube and spout.

FUNCTION

The Rotating Tube is driven by a servo motor. The generated movement is deflected at the bevel wheel by 90° (from horizontal to radial) so that the sprocket executes a rotating movement.

The motion of the servo motor is controlled by Heye Simotion® Servodrive.

For NNPB applications the height adjustment of the Rotating Tube is driven by a stepper motor. The movement generated by the stepper motor is deflected by 90° at the bevel gearing on a threaded spindle drive. The movement of the stepper motor is controlled via the Heye Process Control. The design of the components depends on the Heye Process Control version used.

The height adjustment of the Rotating Tube can either be carried out mechanically via a handwheel or directly from the plant floor via a remote control unit.

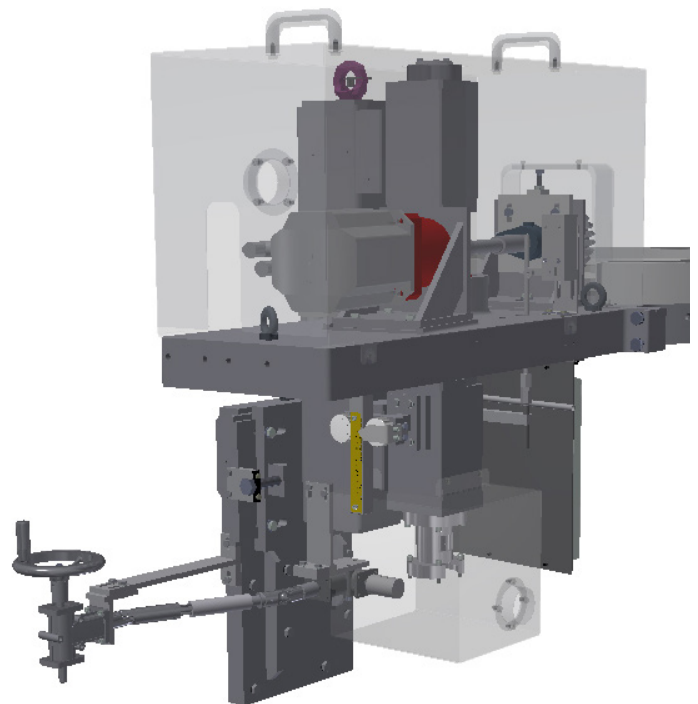

New height adjustment

The height adjustment benefits from the well-proven technology of the Heye Servo Plunger.

The combination of a stable guide with low-backlash threaded spindle drive provides for an exact and reproducible movement of the tube.

For NNPB applications the height adjustment is controlled by the Heye Process Control during run. Manual adjustment is possible by means of an adjusting rod.

CONTROL UNIT

To control the servo motor the Heye Simotion® Servodrive is used. Also please see product description “Heye Simotion® Servodrive”.

Heye Simotion® Servodrive

This highly-flexible control is based on the future-proof multi axis drive System Simotion® from Siemens. Excellent reliability of the electronic components in combination with the application of a compact servo motor with robust resolver guarantee a reliable non-stop operation. Even with respect to servicing this control is perfect as it is easy to handle. If control components should have to be exchanged complicated manual addressing or programming is not necessary because all the configuration data is stored on a memory board. When the control is started the data are automatically transferred. This allows short commissioning and service times and reduces training time for service staff. Fault and operating messages are registered by the control unit with date and time and can be read in detail on the touchscreen anytime.

Lubrication

All guidances and bearings of the rotating tube are supplied with oil via the central lubrication. Lubrication is carried out periodically by the control unit.

Installation

The tube mechanism is fixed with four cylinder screws at a console which is mounted on the face side of the compensation zone.

The local control box has to be arranged in such a way that the Rotating Tube can be observed during adjustment. The control cabinet should be located in an air-conditioned room (see technical data).

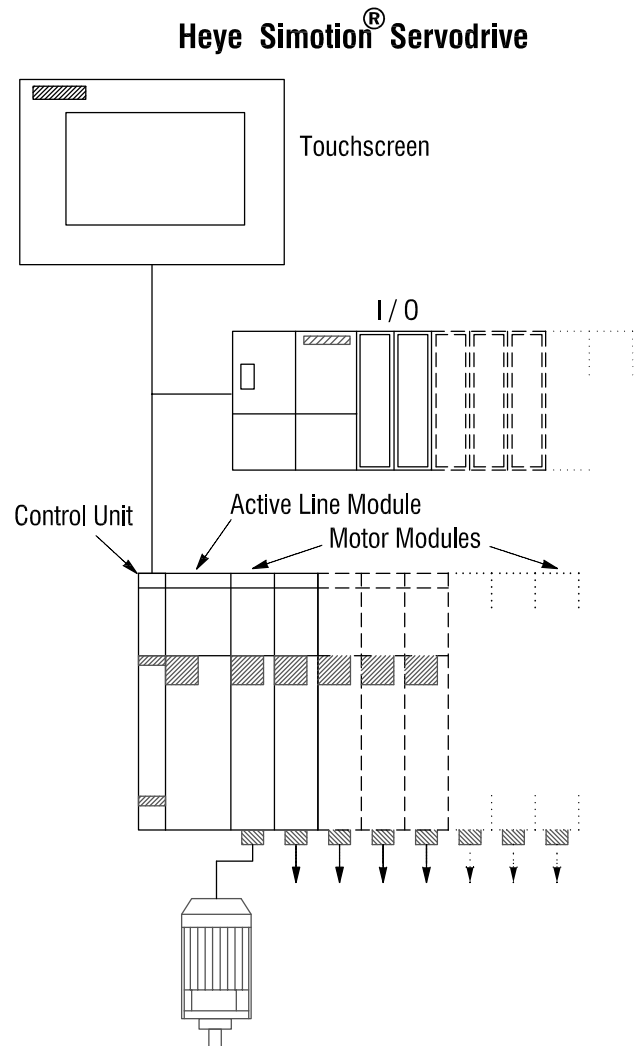

OVERVIEW

Advantages

- Uniform rotation of the tube in the glass
- Stable guide of the height adjustment
- Precise, low-backlash threaded spindle drive
- Electronic height adjustment
- Exact alignment of the tube via cross slide
- Complete housing of the mechanics
- New, temperature resistant and smooth running graphite ring as pivot bearing for the tube

Scope of Delivery

- Rotating tube with feeder connection console
- Mechanical tube adjustment
- Control unit in a closed cabinet, completely wired*
- Local control unit (control box)*
- Set of cables*

Technical Data

- Tube sizes 7", 8", 10", 11", 12" and 13"
- For feeder sizes** 81, 503, 515, 555 and 575
- Weight of the tube mechanism approx. 600 kg
- Dimensions length/width/height 1965 / 710 / 970 mm
- Supplies compressed air 6 bar, fan air 500 mm water column 100 m³/h, connection to central lubrication

* Only in connection with a Heye Simotion® Servodrive control unit.

** Further types possible on request and after technical clarification.

Emissions

- The A-weighted permanent sound pressure level of this system is below 70 dB(A)

Compatible control units*

Heye Simotion® Servodrive

Up to 10 servo axes can be operated (depending on combination of drives and cabinet width)

- Dimensions width/height/depth 800 / 2200 / 600 mm
1000 / 2200 / 600 mm
1200 / 2200 / 600 mm
- Weight 320 - 400 kg
- Power input with two active ventilators depending on the number of axes
- Mains supply three-phase 380 - 480 V ± 10 % PE, no neutral wire
- Mains frequency 50/60 Hz ± 3 Hz
- Mains fuse 35 A slow-blow (to be made available by the customer)
- Ambient temperature for the control unit max. 35°C

Heye Simotion® Servodrive Compact

Up to 4 servo axes can be operated (depending on combination of drives)

- Dimensions width/height/depth 400 / 2200 / 600 mm
- Weight 170 kg
- Power input depending on the number of axes
- Mains supply three-phase 380 - 480 V ± 10 % PE, no neutral wire
- Mains frequency 50/60 Hz ± 3 Hz
- Mains fuse 35 A slow-blow (to be made available by the customer)
- Ambient temperature for the control unit max. 35°C

* For further information on the control unit and respective combination of drives please have a look at our separate brochure.

Illustrations are non-binding and may include optional equipment. Products are subject to continuous technical modifications.

The mentioned consumption values are non-binding and are subject to the customer's individual production program.

0122/Web

Heye International GmbH

Lohplatz 1, 31683 Obernkirchen
Germany

T +49 5724 26 0

F +49 5724 26 539

www.hey-international.com

