

WE ARE GLASS PEOPLE

BLANK MOULD AXIAL COOLING

Type 2242

HiPERFORM

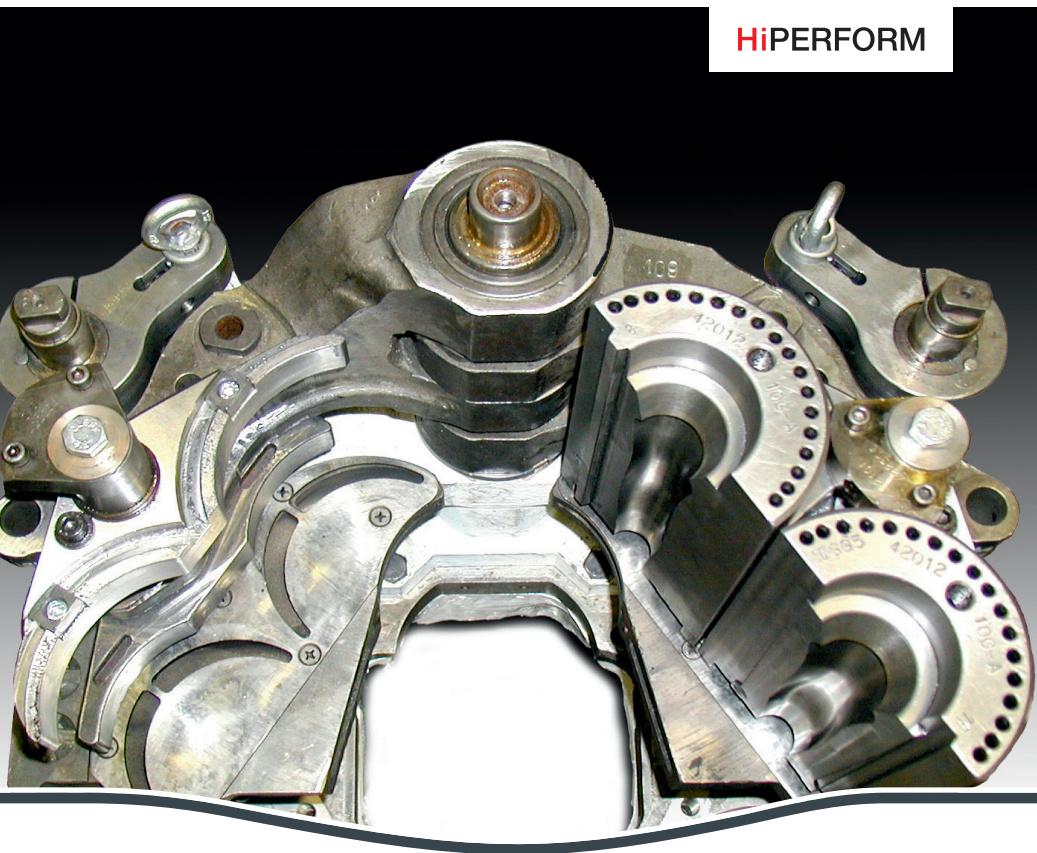

THE BLANK MOULD AXIAL COOLING

is available for 5" DG, 6 1/4" DG and 4 1/4" TG. The system is designed to cool the blank moulds axially and to cool the neck rings radially with fan air in IS-Machines.

Features

For the Blank Mould Cooling high-grade alloy, forged mould holders with non-reverse linkage are used so that the closing movement and the closing forces provide better results than the conventional „reverse-linkage“.

During a job change the axial cooling can be converted to radial cooling by changing the upper assemblies only. Conversions are possible for 5" DG and 6 1/4" DG.

The adaption of the different mould lengths is compensated by the height adjustment of the cooling piece, whereat the neck ring cooling is automatically adjusted, too.

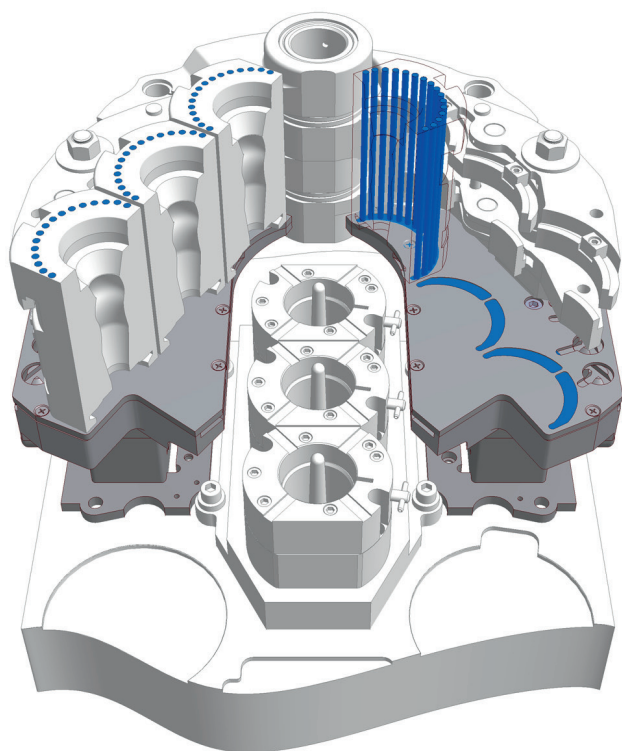

Blank mould axial cooling (4 1/4" TG)

Radial cooling

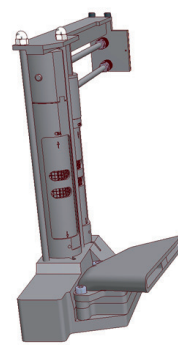

Axial cooling

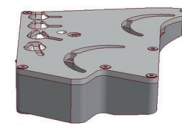

optionally

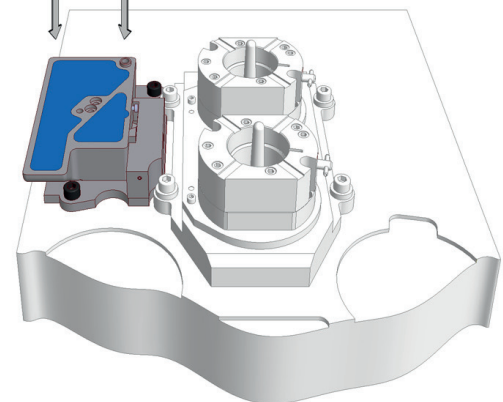

Conversion from axial to radial cooling (6 1/4" DG)

FUNCTION OF THE BLANK MOULD COOLING

The blank moulds are located in opened position above the cooling slots and are supplied with cooling air by an intermittent valve. The neck ring is cooled radially by a separate channel in closed mould position.

Optionally, an additional air box can be installed on the neck ring holder.

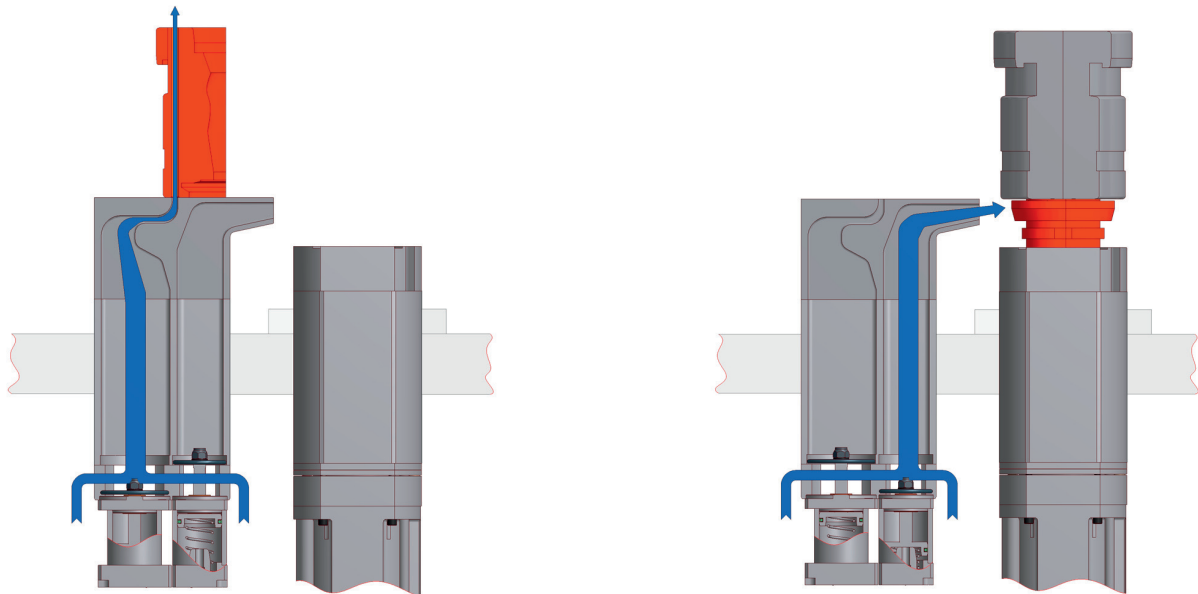

Mould cooling

Neck ring cooling

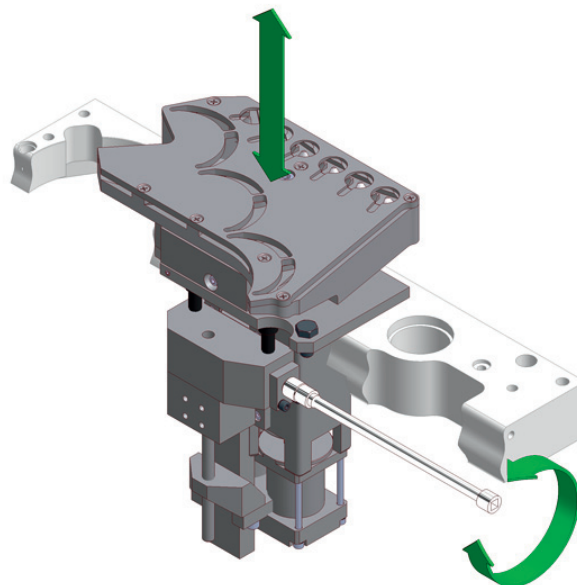

Height adjustment

OVERVIEW

Advantages

- Cools blank mould axially and neck rings radially
- Uses forged mould holders with non-reverse linkage to provide for a better closing movement and higher closing forces
- Retrofit version for existing systems
- Optionally, a stacked cooling (HiFLOW) can be adapted

Scope of Delivery

5" DG

- Blank mould cooling foot
- Blank mould cooling piece
- Complete blank mould holder
- Blank mould shaft unit

6 1/4" DG

- Blank mould cooling foot
- Height adjustment blank mould cooling foot
- Gearing for height adjustment of blank mould cooling foot
- Blank mould cooling piece
- Complete blank mould holder

4 1/4" TG

- Blank mould cooling foot
- Height adjustment blank mould cooling foot
- Gearing for height adjustment of blank mould cooling foot
- Blank mould cooling piece
- Complete blank mould holder