

HiPERFORM

Automatic Press Duration Control



Reproducible Quality

Until recently, the Heye Process Control used sensors to adjust the plunger position in relation to the neck ring tool. This prevented incomplete or overpressed finishes.

A new feature allows you to control time!

Controlled press duration

For the first time ever, With Heye International's Automatic Press Duration Control it is now possible to control the individual phases of the pressing process. // The patented procedure records how long the plunger stays in the glass and then regulates the pressure and time accordingly. Control of the press duration, i.e. the time the plunger remains in the glass, ensures reproducible wall thicknesses. // This is a critical quality feature in hollow glass production.

If the press duration is too short, too much glass flows to the base after delivery of the parison to the blow mould. The result is a thin neck and a thick base. // If the press duration is too long, the outer surface of the parison gets too cold. The parison cannot then reheat sufficiently in the blow mould, so too much glass in the neck and shoulder area and a thin base are inevitable. In extreme cases, if the outer surface is too cold, the glass container can even burst open during the final blow.

The new Automatic Press Duration Control from Heye International makes these article defects a thing of the past.

Control principle

The piston surface of the plunger cylinder is pressurised with compressed air via a proportional valve:

- During the plunger motion time (t_1 to t_2) with a controlled pressure (P_1).
- During the press duration (t_2 to t_3) with a constant pressure (P_2).

After each pressing process the difference between the press duration set-point value and the press duration actual value is determined.

If the set-point and the actual value deviate, the controlled pressure (P_1) is either increased or decreased a little, as required. This control principle ensures that the press duration actual value gradually approaches the set-point value. By controlling the pressure (P_1), it is possible to compensate for the different motion times of the plungers from the loading position to the beginning of the pressing process. Consistent press duration times for all plungers within the machine are therefore achieved. // The constant pressure stage (P_2) determines the force which is used to press the parison against the blank mould profile during the press duration. // A pressure stage (P_3) can be set to cushion the plunger downward movement.

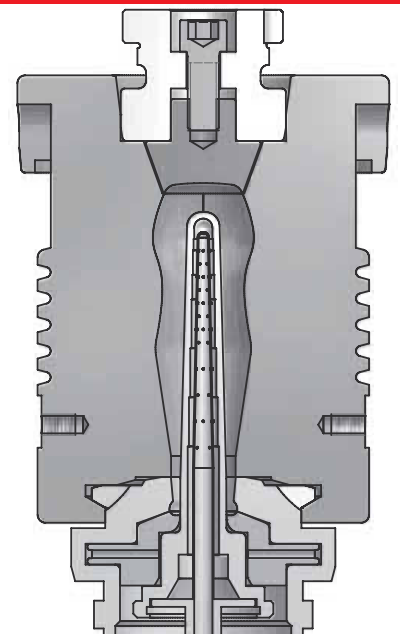

Pressure Course

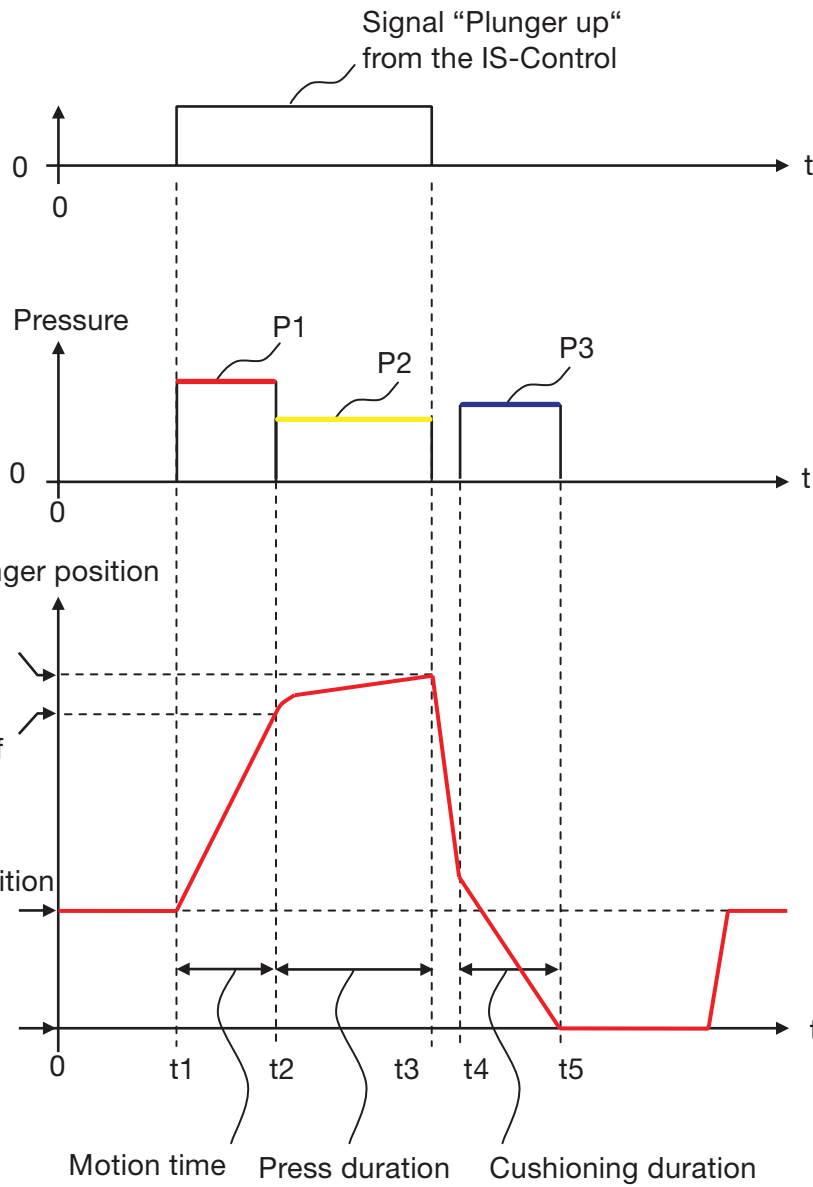

A consistent duration of the plunger within the glass ensures a reproducible wall thickness and therefore high quality.



Optimal Usability

The Automatic Press Duration Control is an optional component of the Heye Process Control.

- A job database enables fast and convenient job changes
- All pressure and time values can be preset on the monitor
- A bar graph of the pressure stages shows potential differences between individual cavities
- Limit value excesses are displayed in plain text
- A pressure sensor in the proportional valve shows the pressure course as a line diagram over time
- Extensive diagnostic tools are included in the package

Retrofit

The Automatic Press Duration Control can be integrated into many existing IS Machines (including those of other manufacturers).



Heye International GmbH
Lohplatz 1
31683 Obernkirchen
Germany

Tel.: +49 5724 26-452
Fax: +49 5724 1288